



This series on Eucalypts has five parts. Each part can be read individually or as part of the series.

1. Overview
2. Establishment
3. Clearwood Production
4. Pulpwood Production
5. Labour Estimates

CLEARWOOD PRODUCTION

Growing eucalypt plantations for high-value appearance grade products requires:

- Pruning to produce clearwood. The cost of pruning for clearwood restricts production to sites with moderate to high productivity where the MAI exceeds 15m³/ha/year.
- Thinning to 150 pruned stems/ha or less at a young age to enable rapid diameter growth and to minimise **growth stress** and **tension wood**.

GROWTH STRESS

With increasing tree age and wood maturity, cells that form new wood under the bark contract longitudinally compared to those formed at a younger age. A tension stress forms along the grain, placing the centre of the tree under increasing compression forces³. *This results in the outside of a log being under tension while the inside is under compression, producing growth stress.* The amount of growth stress can vary between trees of the same species and between species.

Growth stresses result in reduced timber recovery and increased processing costs for a given volume of sawn timber. The major problems for plantation grown logs are:

- **End Splits** - Growth stress can result in end-splitting in logs after felling and in sawn timber during drying, reducing recovery.
- **Distortion During Sawing** - As boards are sawn from a log and growth stress is released, the outer wood (that closest to the bark) contracts, while the inner wood expands, resulting in distortion of the sawn timber. Straightening cuts are required, increasing the cost of processing. Correct quarter sawing techniques result in reduced distortion when compared to back sawing.

While there are techniques to reduce growth stress prior to sawing, the reduction is small. Growers must utilise silviculture to minimise the development of growth stress.

The production of high-value logs from sawlog regimes requires specialised and timely silvicultural activities such as pruning and thinning, usually by age 10. If pruning and thinning are left too late, then smaller log sizes with an increased possibility of growth stresses is likely.

TENSION WOOD

The primary causes of tension wood formation are wind, leaning trees and unbalanced crowns.³ Tension wood results in timber that is very difficult to dry without considerable degrade. Tall, relative small diameter trees can be subject to considerable wind-sway. Bending stresses occur within the stem, resulting in the formation of tension wood in order to counteract these stresses. Leaning trees and unbalanced crowns result in weight imbalances. Tension wood forms on the opposite side to the lean or weight imbalance, in effect trying to 'pull' against the weight.

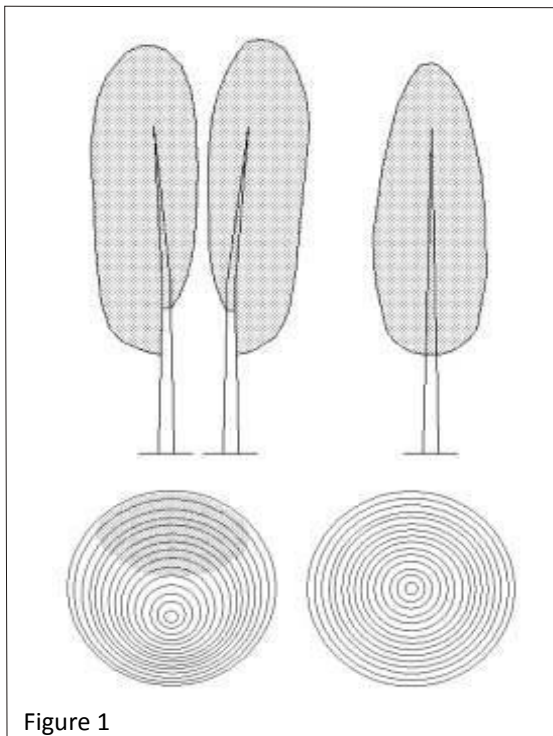

Figure 1

The importance of even tree spacing (Figure 1)

Trees on the left are too close, resulting in unbalanced crowns.

The result is the development of tension wood within the stem. The tree on the right is evenly spaced in relation to its neighbours, resulting in a balanced crown. The lower diagram shows indicative cross sections of stems that correspond to the trees on the left. The shading indicates tension wood that forms within the stem on the opposite side of additional crown development. In such cases it is common for the pith to be off-centre. In effect the tension wood is trying to counteract the weight of the unbalanced crown.

The cross section on the right is indicative of evenly spaced trees with balanced crowns and a central pith. When even spacing is achieved in combination with thinning to low stockings at a young age, tension wood is greatly reduced. Higher quality timber can be produced.

Drying degrade associated with tension wood causes non-recoverable collapse during the drying process, resulting in checking (splits) within the timber. While shrinkage in the longitudinal direction (lengthwise along the grain) and radial direction (at right angles to the growth rings) is not adversely affected, shrinkage in the tangential direction (parallel with the growth rings) is significantly increased compared to normal wood.⁴ While some collapse occurs during the drying of normal wood, it is usually recoverable with steam reconditioning. Non-recoverable collapse results in downgrading of the timber, as it is unsuitable for appearance grade products.

CLEARWOOD SILVICULTURE

Thinning at an early age results in fast diameter growth and shorter trees, compared with tall, small diameter trees from stands left unthinned. New Zealand experience has shown that *fast-grown tall trees* are difficult to mill due to growth stresses, whereas *fast grown, large diameter logs* can remain stable. Eucalypts of the correct species can be grown at 2-3cm yearly diameter increment and be successfully milled and seasoned, provided the correct sawing technique is used².

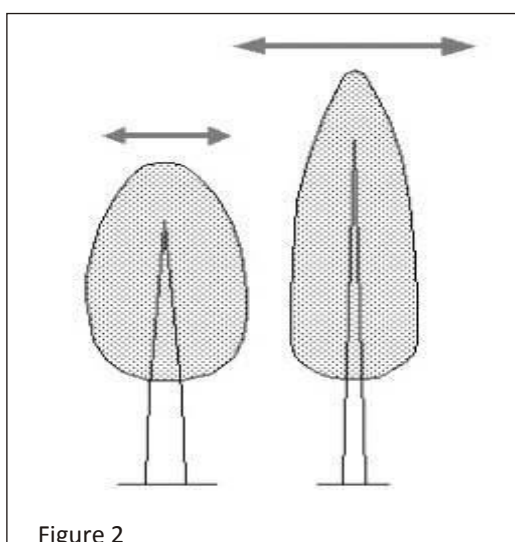

Figure 2

The effect of stocking upon tree characteristics (Figure 2)

Low Stocking - Represented by the tree on the left

1. Fast diameter growth (reduced competition)
2. Reduced height (relatively short, wide crowns)
3. Reduced wind sway (indicated by the arrows)
4. Reduced growth stresses and tension wood
5. Improved recovery of quality timber

High Stockings - The tree on the right

1. Slow diameter growth
2. Increased tree height
3. Increased wind sway
4. Increased growth stress and tension wood
5. Reduced recovery of quality timber

Figure 3

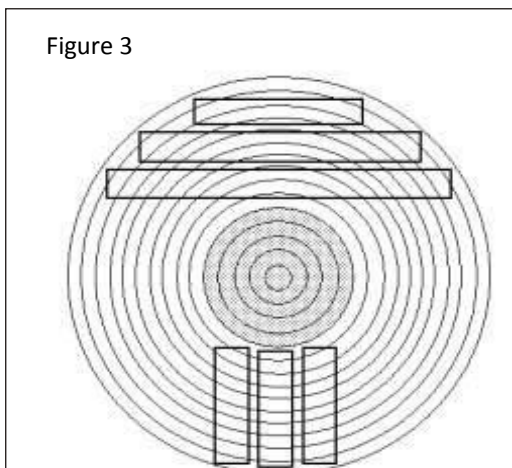

The importance of attaining large diameters (Figure 3)

Back Sawing (top) enables wide boards to be cut from relatively small diameter trees. Growth stress and tension wood can result in significant sawing and drying difficulties.

Quarter Sawing (bottom) is the preferred sawing option for eucalypts with growth stress and tension wood. Drying degrade can be significantly reduced. However, wide boards can only be cut from large diameter trees. *Shading represents the defect core.*

A reduction in growth stress is achieved with fast diameter growth. Log diameter is important when sawing

eucalypts.⁵ The amount of growth stress present is determined by tree age, rather than growth rate. The outside of a log is under tension, while the inside is under compression. This results in a stress gradient between the centre of the tree and the outer periphery. A small diameter tree will have a similar level of growth stress to a large diameter tree of the same age. The growth stress within the larger diameter tree is spread across a greater distance, resulting in a relatively flat stress gradient. As a result, there is less distortion during sawing.⁵

This is supported by Australian research, with sawing and drying studies indicating that the production of high quality timber from *E.globulus* and *E.nitens* occurs when stands have been heavily thinned at an early age. When quarter sawing strategies are applied, appropriate drying schedules can almost eliminate drying degrade.³

PRUNING FOR CLEARWOOD PRODUCTION

Unlike softwood species such as *Pinus radiata*, eucalypts do not tolerate intense between-tree competition. In order to achieve large diameter trees in relatively short rotations, a final stocking of 150 stems/ha or less is recommended. This requires an average spacing of 8 metres or more between trees. Pruning is usually carried out in 'lifts' of about two to three metres with three lifts often occurring on selected trees at a frequency determined by the growth rates of the stand.

Pruning Objectives

- Select trees with suitable spacing, form, and vigour.
- Achieve a consistent maximum Diameter Over Stub (DOS) of approximately 15cm for all lifts. Pruning to achieve a maximum DOS significantly smaller than 15cm achieves little with respect to clearwood recovery while tree growth can be adversely affected.
- Prune live branches (green pruning) to minimise the defect core.
- Prune when branch size is small (<3cm) to reduce the size of the pruning wounds and increase the rate of occlusion (healing) of pruned branch stubs.
- Retain sufficient foliage to maintain growth rate to ensure rapid occlusion.

DOS (Diameter Over Stub) refers to the diameter of the stem at the point of pruning, including branch stub. The largest DOS within the pruned stem, plus some additional growth to occlude the pruned branch stub fully determines the ultimate size of the defect core. Ideally, the defect core should be a straight cylinder with a diameter of 20cm or less. Clearwood is then formed beyond this defective core.

Containing the Defect Core

The size of the defective core is restricted by:

- Selecting trees with suitable form.
- Pruning at appropriate intervals.
- Pruning green branches, not dead branches.

Green Pruning

Knots and associated defects are the major limiting factor to the recovery of appearance grade products from plantation grown eucalypts. *E.globulus* and particularly *E.nitens* exhibit poor self-pruning and do not effectively shed their branches at normal plantation stockings. The pruning of dead branches does not reduce the size of the knotty core compared with that achieved with self-pruning¹. In order to minimise the size of the knotty core, branches should be pruned when they are alive.

Pruning and Growth Rates

Pruning has the potential to reduce growth rates. Studies into the pruning of *E.nitens* in Tasmania suggests that removal of 50% of the green crown can be performed without loss of growth. However, removal of 70% significantly reduced tree growth¹. These results were found for the first lift and apply to the depth of the green crown rather than the percentage of foliage removed. At present it is not known how the pruning of later lifts will affect growth rates.

Pruning and Potential Decay

Pruning can allow the entry of fungal diseases and potential decay within the tree. Evidence suggests that rapid occlusion of pruning wounds and reduced decay occurs when branches are removed when less than 3cm in diameter, while pruning larger branches may increase the incidence of decay¹. Provided quality pruning standards are maintained, internal decay is expected to be contained within the knotty core, with no evidence to date to suggest that it spreads to the clearwood zone.

Pruning Frequency and Timing

Annual clearwood pruning from age 3-4 in late winter or early spring is recommended.

- Branches can be removed while they are small (<30mm), increasing pruning efficiency and the rate of occlusion.
- Pruning wounds have a full growing season in which to occlude, with continuous growth from spring through to autumn.
- The need for pruning dead branches is reduced.
- The DOS is maintained within above pruning objectives

NB Stands should be assessed for form and clearwood pruning requirements on an annual basis from age 2 onwards. Growth rates, particularly on high quality sites, can be rapid and delaying pruning by 6-12 months can jeopardise containing the defect core.

Form Pruning

Form pruning may be necessary where poor form, low initial stockings or poor survival rates result in a low selection of trees with suitable form, vigour and spacing. Form pruning should concentrate on:

- Removal of double leaders and high angled branches. It is recommended that assessment for form and spacing be undertaken at age 2 when it can be conducted with relative ease from the ground. Form pruning later than age 2, particularly on the lower stem, may not be effective.
- Shortening or removing large vigorous branches above the height of current clearwood pruning. Such branches will often exceed 3cm in diameter if retained until the next clearwood pruning lift.

Variable Lift Pruning

Variable lift pruning is recommended and ensures that the defect core is a consistent size for all trees. The easiest method to ensure that all trees receive a similar level of pruning is to use a stem calliper. For most sites, a 10cm calliper is considered adequate and is placed around the stem to identify the point below which all branches are to be removed by pruning.

Minimum Distance between Pruned Trees

It is recommended that the minimum distance between pruned trees, regardless of final stocking, should be about 6 metres. Unbalanced crowns and tension wood can form if trees are too close.

Pruning Equipment (high quality pruning equipment is recommended)

- a. Small Bypass Loppers - Form and clearwood pruning.
- b. Hand Saw - Removal of large branches where late pruning is undertaken or where rogue branches have developed rapidly.
- c. Pruning Holster - Loppers and hand saw carried in the holster.
- d. Pruning Ladders - Lightweight aluminium forestry ladders in 2.4m and 4.2m lengths. Extension type ladders may be useful for variable lift pruning.
- e. Safety Harness - When pruning from a ladder a safety harness should be used. Although pruning rates may be slower with a harness, safety is more important than getting a few extra trees pruned. A full body harness designed for working from ladders should comply with AS/NZS 1891.1:1995.

Discuss pruning equipment with PFT staff or pruning contractors prior to purchase. It is advisable to attend field days and training to ensure correct pruning techniques and safety procedures.

THINNING REGIMES FOR CLEARWOOD PRODUCTION

- Non-commercial thinning of all unpruned stems should be done at, or prior to, the completion of pruning to 6.4m. This is recommended for smaller areas.
- Commercial thinning usually occurs at age 10-12 and should be in combination with an earlier non-commercial thinning at, or prior to, the completion of pruning to 6.4m. Retaining all unpruned stems until commercial harvesting may increase potential windthrow of pruned stems, while non-commercial thinning to release pruned stems from competition ensures rapid diameter growth and the rapid occlusion of pruning wounds.



Pruning and thinning for clearwood

The photo is of a small plot of seven year old *E.nitens* at Private Forests Tasmania's Demonstration Site at Claude Road, Sheffield. Trees have been pruned to a minimum of 6.4 metres and all unpruned stems non-commercially thinned. Stocking is approximately 250 stems/ha and further thinning to about 150 stems/ha is planned.

Thinning & Branch Development

Due to the low final stocking required to grow large diameter eucalypt sawlogs, the unpruned stem above the pruned butt log is likely to develop large branches, particularly when non-commercial thinning of all unpruned stems occurs very early in the rotation. Potential pulp logs with excessive branching may require manual delimiting should branches be too large for mechanical harvesters, thus increasing harvesting costs and reducing stumpage to the grower.

Non-commercial thinning to a moderate stocking of about 500 stems/ha, followed by commercial thinning at age 10-12, is likely to restrict branch development above the pruned butt log and may provide an early cash flow. Commercial harvesting may be restricted to sites greater than 5-10 hectares which are easy to harvest and relatively close to markets, due to the relatively small volume of pulpwood from such a regime (less than 100 tonnes per hectare).

The following example is an option that combines non-commercial and commercial thinning. The aim is to achieve a relatively even spacing of pruned stems throughout the plantation.

Year	Time	Silvicultural Operation
-1	~12 months prior to establishment ~6 months prior to establishment	Obtain planning permission from local council (if required) Undertake site planning (mapping of area, weed species, etc.) Pre-planting weed control - Spray difficult to control woody weeds such as blackberry and gorse (if present). Order seedlings Forest Practices Plan (if required) Determine method of browsing control and obtain permits if required.
0	Summer Autumn Autumn to Spring	Graze the site heavily to reduce pasture species Arrange site inspections and quotes from contractors for establishment. Mark planting lines for initial spraying operations. Pre-planting weed control (pre-cultivation) - Strip spray the planting lines with knockdown herbicides. Cultivation - Ripping and mounding prior to the autumn break. Fencing to exclude stock / browsing animals. Browsing control Pre-planting weed control - Apply residual herbicides to planting mounds. Planting at desired stocking (eg: 1,000 stems/ha) Fertilising 6-8 weeks post planting and ensure that weeds are adequately controlled prior to fertilising.
1	Early Summer	Stocking survey - Determine seedling numbers if re-planting is required (determine reason for failures and address the issue if possible)
1+	Autumn - Spring Ongoing	Re-planting (if required). Post-planting weed control - Spot or strip application. Monitoring - Annual inspections for pests and diseases.
2	Spring	Form pruning - Remove double leaders and excessive branches.
3	Spring	First Lift - Variable Lift Pruning (~200 stems / ha).
4	Spring	Second Lift - Variable Lift Pruning (~175 stems / ha).
5	Spring	Third Lift - Variable Lift Pruning (~150 stems / ha).
6	Spring	Final lift - Variable Lift Pruning. Conducted on those trees not yet pruned to 6.4m during the third lift. Non-commercial thinning - Release of pruned stems. (can be performed at an earlier age)
8	Winter	Inventory to estimate stand volumes, growth rates, appropriate thinning age and potential volumes for commercial thinning.
9	12-24 months pre-thinning	Marketing - Arrange sale contract and harvesting contractor. Forest Practices Plan (required for commercial thinning).
10	Dry conditions	Commercial thinning.
23	Winter	Inventory to estimate standing volumes, growth rates, appropriate clearfell age and potential volumes at clearfell harvest.
24	12-24 months pre-clearfell	Marketing - Arrange sale contract and harvesting contractor. Forest Practices Plan (required for clearfell harvest).
25	Dry conditions	Final harvest

SUMMARY

- Clearwood regimes require a low final stocking of 150 stems/ha or less to achieve large diameter trees with minimal growth stress and tension wood.
- Prune dominant and co-dominant trees with good form, vigour and spacing.
- Maintain the defect core to about 15cm to maximise clearwood recovery.
- Pruned trees should be no closer than about 6 metres at the completion of pruning to 6.4 metres to avoid unbalanced crowns and the formation of tension wood.
- Undertake non-commercial thinning of all unpruned stems at the completion of final lift pruning on sites where commercial thinning may not be viable.
- Commercial thinning at age 10-12 following early non-commercial thinning to about 500 stems/ha may be possible. Commercial thinning may be restricted to larger sites (>10 hectares) with low harvesting and transport costs to ensure adequate volumes and reasonable returns to the grower.

FURTHER READING

Montagu, K., Kearney, D., and Smith, G., (2003). Pruning Eucalypts - The biology and silviculture of clearwood production in planted forests, Rural Industries Research & Development Corporation. (www.rirdc.gov.au/reports)

Barr, N., (1996). Growing eucalypt trees for milling on New Zealand farms, New Zealand Farm Forestry Association.

Washusen, R., (2001). 'Is high quality solid wood from blue gum plantations a realistic option?' Agroforestry News, 10, Issue 3, pp. 22-23.

Bootle, K.R., (1983). Wood in Australia, Types, properties and uses, McGraw-Hill Book Company, Sydney.

Haslett, A.N., (1988). A guide to handling and grade-sawing plantation-grown eucalypt, FRI Bulletin No. 142. Forest



Hobart: 6165 4073
Launceston: 6777 2720
Burnie: 6477 7052
admin@pft.tas.gov.au
www.pft.tas.gov.au
© Private Forests Tasmania 2016

This information has been prepared by Private Forests Tasmania. Every reasonable endeavour has been used to ensure that the material was accurate at the time of publication. However, Private Forests Tasmania takes no responsibility for the accuracy, completeness or relevance of such information or for matters arising from changed circumstances or information or material which may have become available subsequently. This information is introductory in nature and should not be treated as a substitute for specific advice or relied on as a basis for business decisions. Before undertaking any significant forestry project it is recommended that you seek personal professional advice directly from a forestry professional on the particular matter.